

5TH GENERATION LINEAR EDM



AG400L

AG600L

Linear Motor Drive,
High Speed Wire-cut EDM
With LN2W and LP2WH
Control Systems



Sodick

Nano&Solution

The World's First 10-Year Positioning Accuracy Guarantee

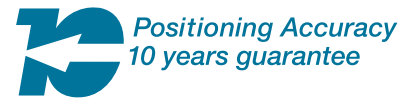

Utilising the linear motor drive system, Sodick wire-cut EDMs have enabled difficult machining operations that were not possible with conventional ball screw-type EDMs, resulting in the cumulative shipment of more than 24,000 units by early 2010.

The linear motor-driven EDM, eliminates the need for ball screws and allows for non-contact motion. Use of the Linear Motor removes the deterioration in machining accuracy caused by the worn ball screw assemblies throughout the machine life. Sodick's confidence in the performance and accuracy of their machines over a 10 year period allows them to be the only manufacturer to offer a 10 year positioning accuracy guarantee on all their Linear EDM Machines.

The 5th Generation Linear EDM Has Arrived

Since the launch of the world's first linear EDM machines in 1999, Sodick has constantly improved and further developed this unique technology. With over 24,000 machines installed around the world, this latest series of EDM machines represents the 5th generation of Sodick linear technologies.

10 years of linear EDM experience and know-how at your finger tips.





Energy Saving Designs And Technologies



Compared with conventional EDMs, the Sodick Wire EDM Range can reduce the average energy consumption by up to 60%. The newly developed power supply series efficiently supplies discharge energy and linear motor control current through the resistor free circuit.

Furthermore the energy used in the manufacture of the actual component parts is dramatically reduced as the linear motor drive systems require fewer mechanical components and do not need to be replaced regularly due to wear.

Standard Features

High Rigidity

Sodick's expertise in EDM innovation using 3D design systems, the latest CAE technologies and numerous simulations have made it possible to create an improved basic machine structure of optimised rib arrangements which increase rigidity by approximately 70%. Deformation is minimised, allowing optimum performance of high-speed and rapid acceleration linear motors. Furthermore the original design of an independent X and Y-axis plus an efficient machine layout lead to a longer stroke, smaller footprint and highly accurate machining capability.



Tech 1

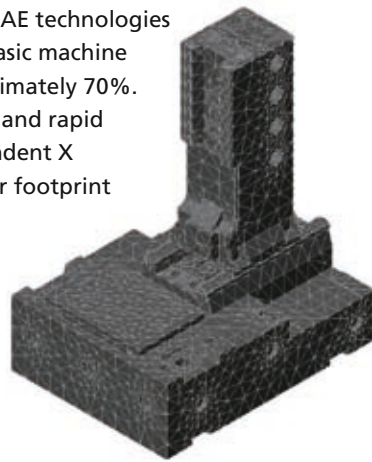

Sodick's New Efficient Power Supply Unit

The AG wire EDM series profits from Sodick's latest generation of power supply unit, which is capable of high-speed, high precision and high-efficiency machining. An NC control system based on modern operating system used in conjunction with the power supply delivers outstanding results. The user interface benefits from a 15" colour touch screen for ease of use and operation.

Tech 2



Linear Motor Drive

Sodick's linear motor is a direct drive, vibration free device which has unrivalled acceleration and positioning accuracy with no backlash. Its high dynamic responsiveness, stability for precision machining, and performance do not diminish over time and remain maintenance free. The linear motor achieves even better performance thanks to the Motion Controller (K-SMC) which Sodick has perfected over the years.

Tech 3

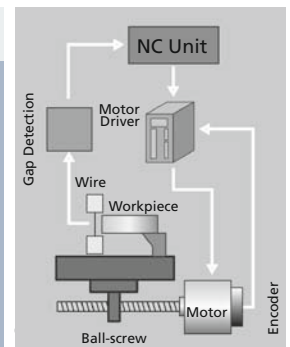
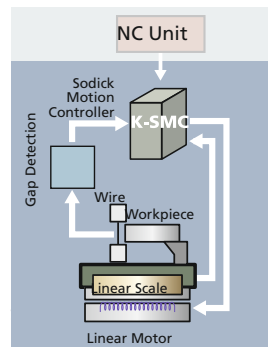
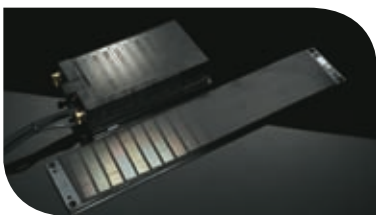

Absolute Linear Scales

With the introduction of new advanced absolute linear glass scales the need for referencing has been removed. Therefore, ensuring total positional control at all times and reduced setting up time.

Ceramic Components

The AG400L and AG600L wire EDMs are constructed using ceramic components for the work stand table and critical parts, all of which are built in-house to ensure high precision machining with better electrical insulation, abrasion resistance and rigidity. Ceramics are ideal for high precision machining due to their very low thermal expansion co-efficient (less than one third than that of cast iron), high rigidity and resistance to ageing.

Tech 4





Aero Harmonic System

Tech 5

By circulating the dielectric fluid through the critical components of the machine in combination with a controlled force air flow, the machine body is harmonised with the room temperature.

The internal and external temperatures of the casting are standardised, and the optimally-designed covers assist the efficient temperature control. The insulation material which covers the entire column insulates against the outer air from affecting the temperature within the column. The Aero Harmonic System in the machine minimises the thermal influence from various production environments.

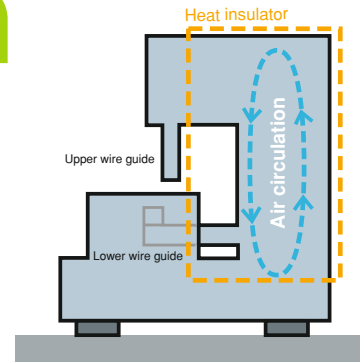

Tech 6

Electrolysis Free Machining

Sodick created the electrolysis-free circuit to prevent oxidation, deterioration and pitting corrosion of the workpiece. A high frequency bipolar pulse passes between the electrode and workpiece eliminating bias and allowing ultra high speed machining without electrolysis.

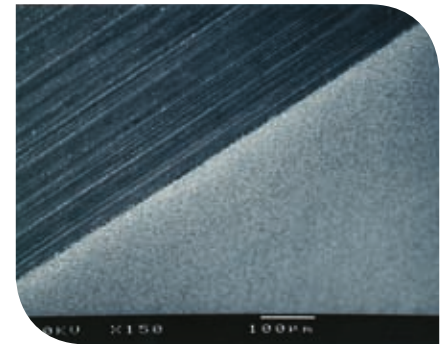

Effects Of Electrolysis Free Circuit

- **Cemented carbide:** minimises the depletion of cobalt which is the binder of the material and preserves the integrity of the material surface.
- **Ferrous material:** reduces rust and corrosion, prevents discoloration of the workpiece during long machining operations.
- **Titanium alloy:** reduces anodisation and oxidation, therefore preventing discoloration of the workpiece.
- **Aluminum alloy:** prevents corrosion and discoloration of the workpiece caused by machining waste.
- **PCD:** minimises the depletion of the workpiece binder, prevents corrosion and preserves material surface integrity.

Automatic Wire Threading With "Super Jet AWT"

Tech 7

In Sodick's original automatic wire threading unit (Super Jet AWT) – the pipe guide runs between the upper guide and lower guide and reliably threads the wire.

- AWT automatically prevents any short-circuit after re-threading, ideal for unattended machining
- The wire is cut by a thermal process, which sharpens the cut end of the wire, thus further improving the threading success rate.

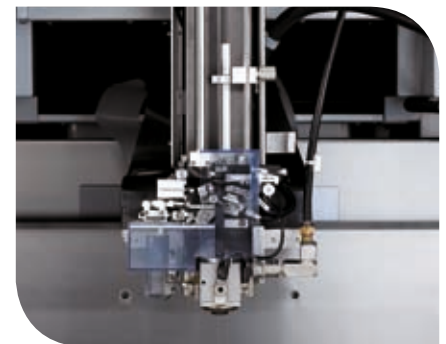

Wire Tension Servo

Tech 8

All AG series machines are equipped as standard with a wire tension servo to continually monitor and regulate wire tension and adjust the servo motor current, which makes stable, high precision machining possible.



In Pursuit Of High Efficiency, Easy Operation and Low Maintenance

The design of the new AG series is focused on ergonomics to allow optimum use of machine capabilities. The operator will find the machine easy and simple to work with from preparation to machining. Sodick machines are also designed to be energy efficient, ensuring cost-effective machining at all times.

Ergonomic Setup Features

Automatic 3-sided drop tank:

Excellent accessibility to worktank

Automated fluid level control:

Efficient control of dielectric level

4-sided frame type worktable:

Maximum productivity

Ergonomic hand held control panel:

User-friendly operation

Dynamic collision protection system:

Linear motor instant response

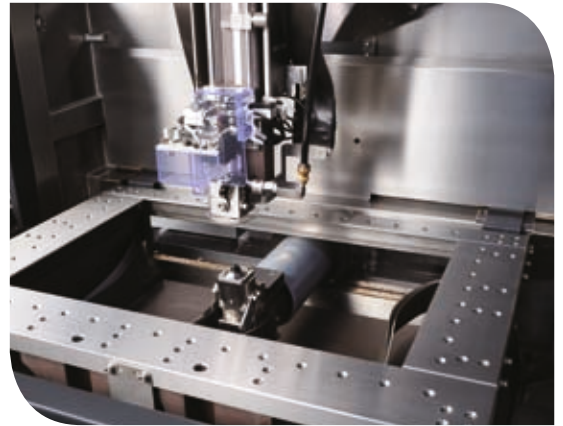

Triple Filtration System

An extensive improvement in filtration capability makes high speed and accurate machining easier to achieve. The filters can even be changed during machining. A recyclable Eco Filter is also available.



Wire Ejection Unit

A low-friction roller and extremely rigid unit have led to improved reliability. Additionally, the roller can be shifted in 5 positions, which significantly reduces the need for replacement.

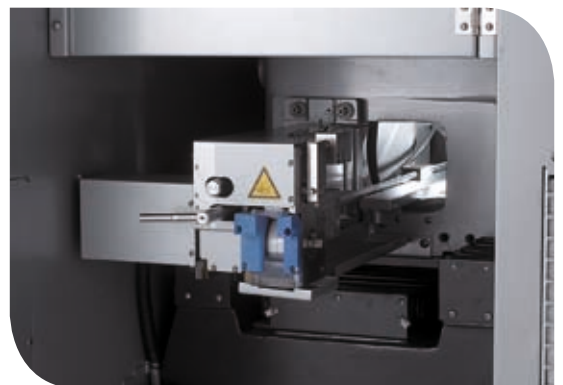

Slide-Plate Flushing Function

A seal flushing function has been introduced to support the machine's capability for high precision, stable machining. This also provides for easier maintenance and extends the life of the tank seal.



Maintains A Continuous High Level Of Precision

A linear motor drive machine retains its precision accuracy and high level capabilities over a long period of time. The rigid design and broad scope of possible applications allow Sodick machines to meet the varying demands of contemporary manufacturing and respond to the customer's needs.



Pitch And Form Accuracy

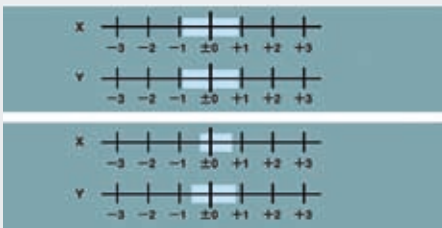
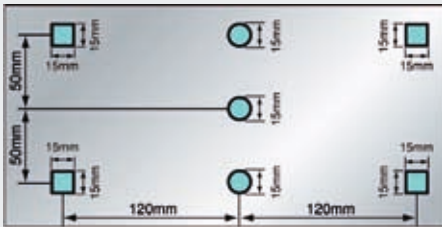

- Workpiece material: SKD-11, t=15 mm
- Wire diameter: \varnothing 0.2 mm

Improved Corner Accuracy (sharp edge and no rounding of corner)

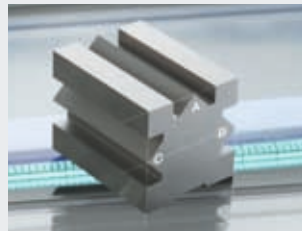

High accuracy with corner control

- A: Sharp edge R 0.010 mm
- B: Point R 0.010 mm
- C: Point R 0.030 mm

At every machined corner Sodick achieved a very precise corner radius. The error from the target amount was less than 1.0 μ m at every corner.

- Work piece material: SKD-11
- t = 20 mm
- Wire diameter: \varnothing 0.2 mm

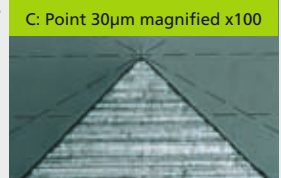
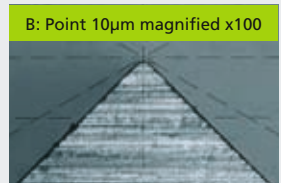
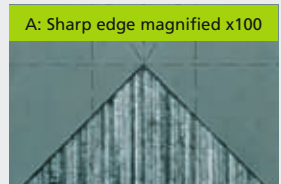

Circular Accuracy



- Workpiece material: SKD-11, t=40 mm
- Wire diameter: \varnothing 0.2 mm
- Circular accuracy: 0.82 μ m

True Direct Precision

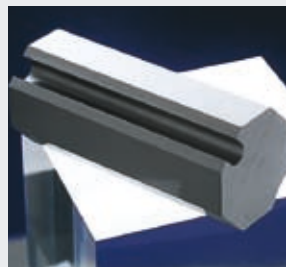

- Workpiece material: SKD-11
- t = 50 mm
- Wire diameter: \varnothing 0.2 mm
- Form accuracy: (distance across flats 20 mm, octagon condition)

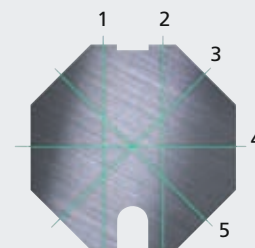

	Top	Middle	Bottom
1	20.001	19.999	20.001
2	20.000	20.000	20.001
3	20.001	19.999	20.001
4	20.001	20.000	20.001
5	20.002	20.001	20.002

The cutting was conducted according to Sodick machining conditions.

Work Samples AG400L/AG600L



Slide Machining Of High Grade Materials

Interlocking workpieces, long workpieces and punches with different top & bottom contours can be machined to an even greater accuracy by using the "Taper Flex" option. This function also significantly increases the scope of potential applications for mould manufacturers.

- Workpiece material: SKD-11,
- t=120 mm
- Taper angle: 7 degrees

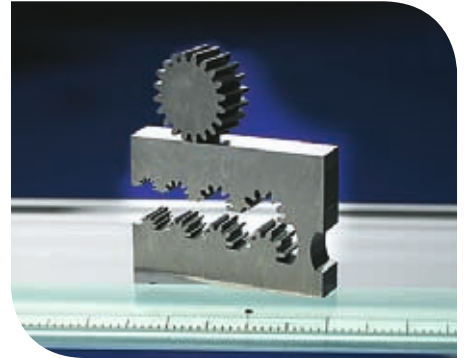
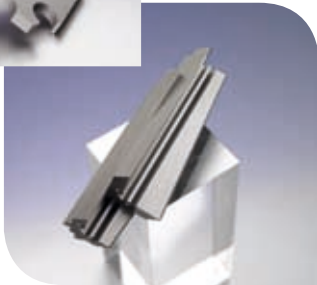

High Accuracy Gear Machining

Sodick's advanced corner control function enables the machining of high precision corners.



Interlocking Thick Workpieces

The AG wire series can easily produce a high-level interlock.

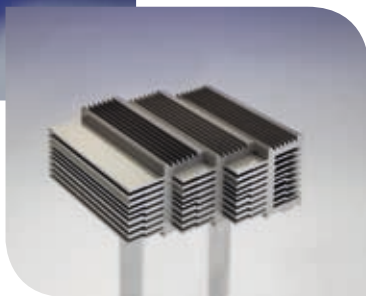

Diamond Tool Machining

By installing a high-quality power supply for EDM, surface damage such as chipping and cracking is minimised and the high speed cutting of difficult to machine materials is made possible. Moreover, tools such as cutting tools and router reamers can be produced by using an indexer and rotary axis.

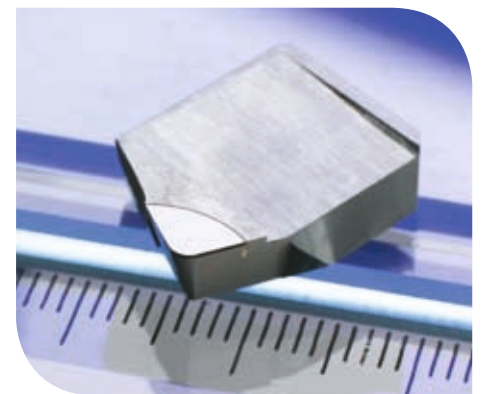

Motor Core Machining

Excellent form accuracy can be attained with minimum interlocking clearances, even on oversized workpieces, eg: 100 mm x 100 mm.

Sample of electric car motor core

- Workpiece material: SKD-11
- Clearance: 2.5 μ m
- Punch: t=50 mm, surface roughness 0.15 μ mRa
- Die: t=30 mm, surface roughness 0.14 μ mRa
- High precision machining for long periods



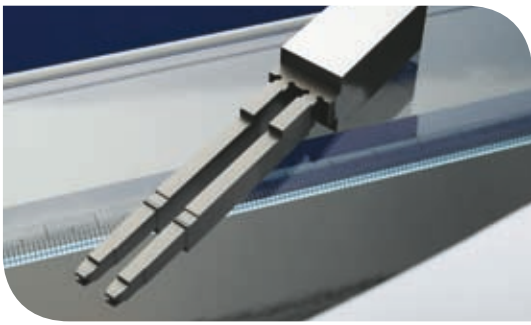

Machining Of Connector Core Pin

Shapes with high aspect ratios are usually affected by warping or bending, but digitising the discharge energy solves the problem and allows stable and high accuracy machining.



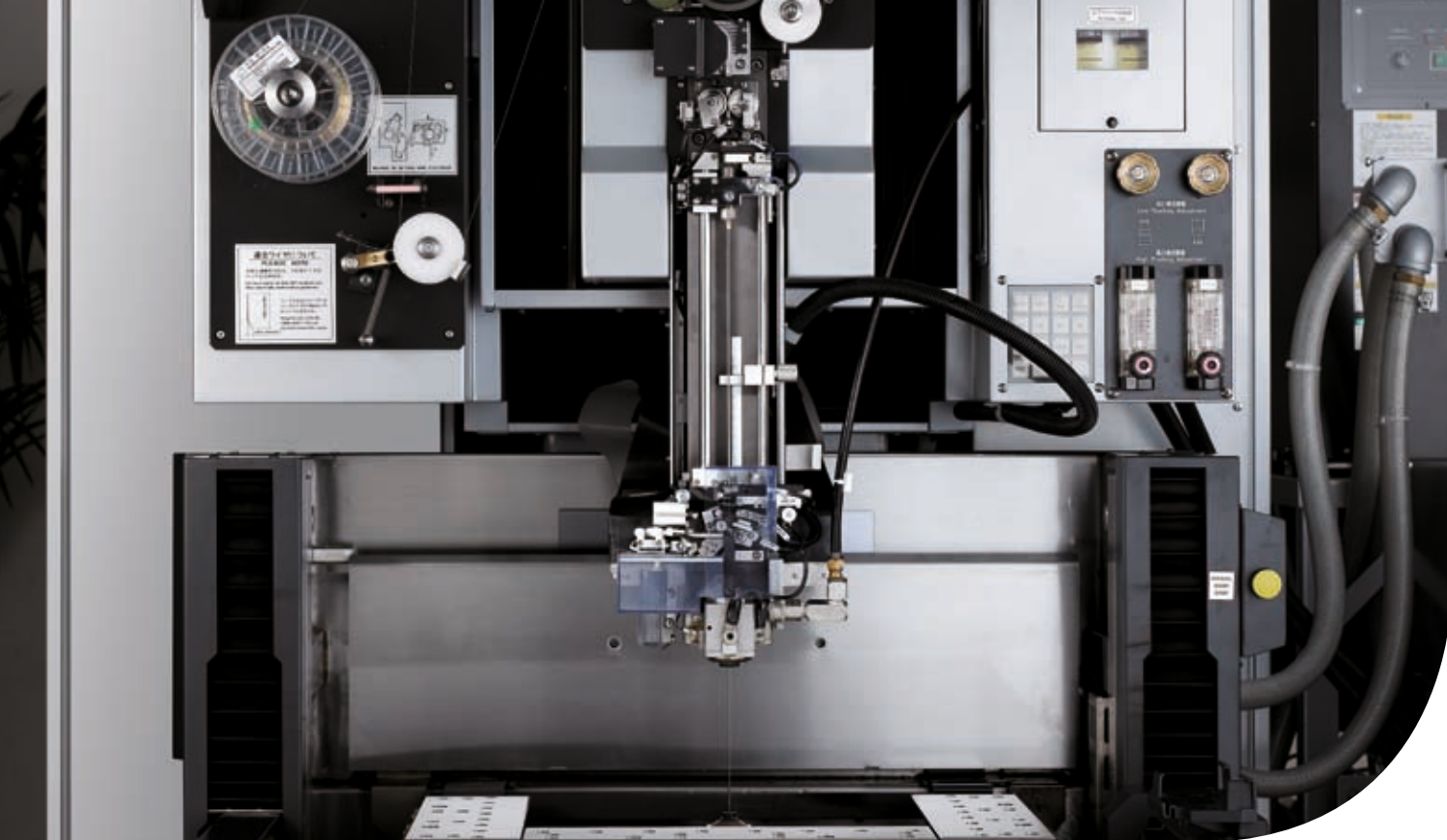

PREMIUM FEATURES

Technology Capable Of Supporting World Leading Manufacturers

The new models are developed to achieve even higher precision, easier operation, higher cutting performance and higher stability than the previous models.

PREMIUM 1

Best Surface Finish Of Less Than 0,1µm Ra

"Super Pika-W" is the super finish circuit which Sodick has introduced. Super Pika technology was created and developed by Sodick to minimize machining energy, resulting in an excellent surface finish which significantly reduces and in some cases eliminates the need for subsequent polishing and other finishing operations.

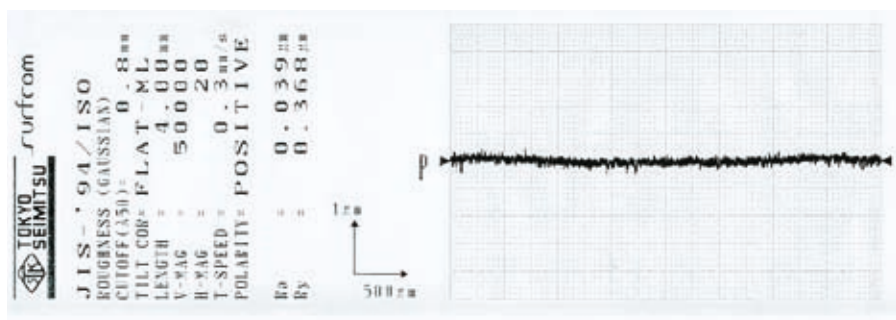
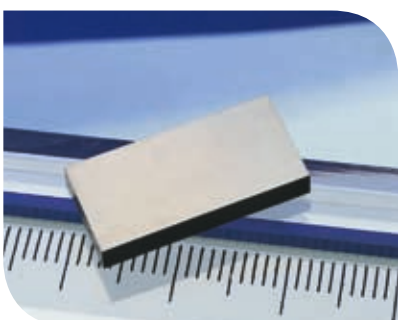
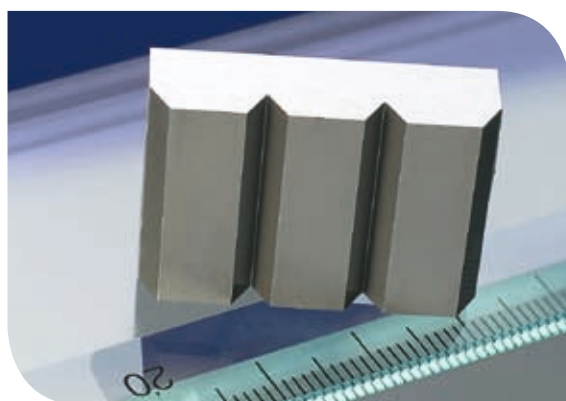

PREMIUM FEATURES

PREMIUM 2

Complex Geometry Machining

Sodick's "Thinking Circuit 2" automatically detects the thickness of the workpiece and calculates the optimum machining settings from rough machining to finishing for every thickness, avoiding wire breakage. Furthermore, parallelism of 1-2 μm can be achieved.

The "Thinking Circuit 2" ensures even more stability, high speed and high precision for the machining of stepped or irregular parts.

- Workpiece material: SKD-11
- Thickness: 20 to 80mm
- Wire diameter: \varnothing 0.25mm

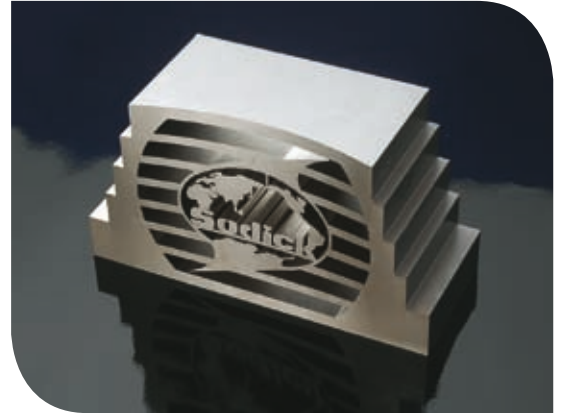

"Intelligent Q³vic EDW"

Intelligent Q³vic EDW is standard with Premium series. This automatic programming system detects area of a workpiece that can be machined with Wire-EDM and extract the machining contour at a time. Drastic reduction of man-hour is possible thanks to the function that extracts a machining contour of even a complicated shape with only one command.

PREMIUM 3

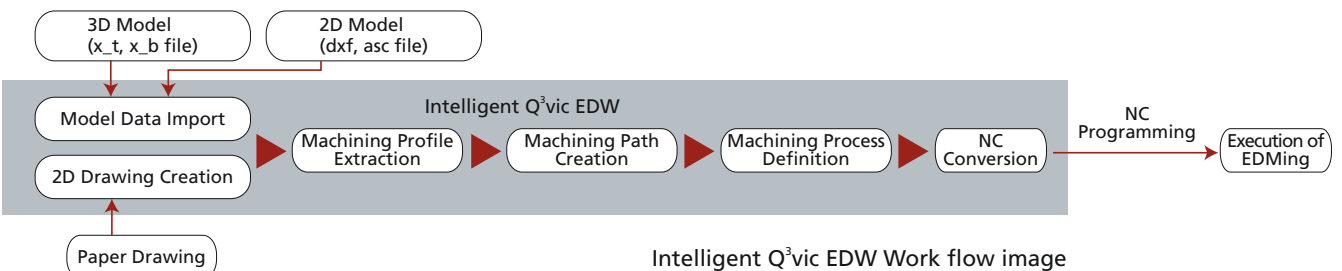
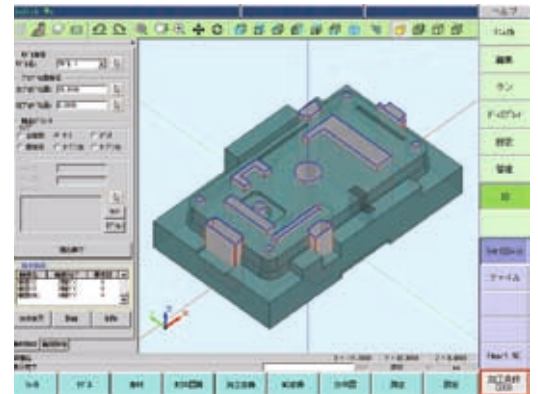

High Speed Generator

PREMIUM 4

The Premium series are equipped with the latest generator LP2WH, which has a significant cutting speed advantage over previous generations of power supplies. This advanced generator delivers truly outstanding results with both standard brass and coated wires.

Options

Taper Flex 45

Taper Flex 45 is available as an option for further advanced high angle taper cutting up to 45°. Taper Flex 45 is easy to use and requires no special training. The function consists of three parts, high angle guides, and compensation jig and specialised software.

OPTION 1

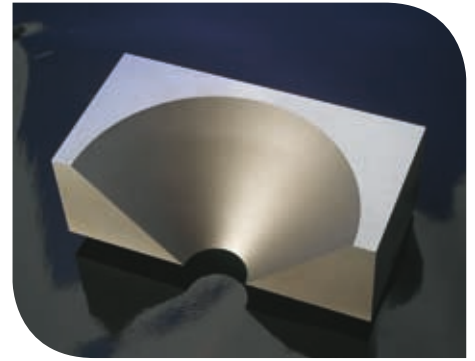

Jumbo Feeder

The wire supply device allows up to 50 kg wire bobbin as standard and supports continuous machining.

OPTION 2

L-Cut (Wire Chopper)

Part of the ejected wire is chopped into small pieces for easy disposal.

OPTION 3



Automation System

AG400/600L is compatible with Robot automation systems. Left handed CNC specification is also available for multi-automation as factory option.

OPTION 4

WS-4P/5P

Sodick's own Rotary Table developed In-house is available as an additional A or B axis for indexing or simultaneous contouring.

OPTION 5

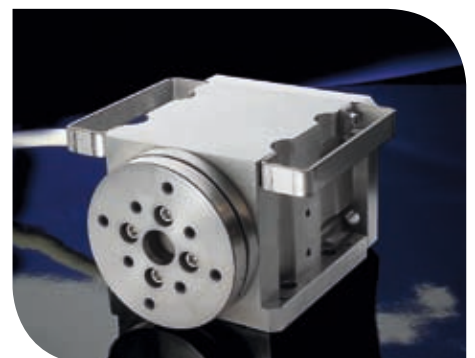

Options

OPTION 6

Multi-axis Control

Factory option of Sodick power supply "LP20W / LP20WH" is capable of controlling an 8 axis simultaneously.



OPTION 7

ANCS (Anti Corrosion System)

For Premium series, Sodick's new developed ANCS (Anti Corrosion System) is available as an option. The ANCS prevents rust, corrosion and discoloration on workpieces while they are being machined or left in the dielectric. This advanced Rust-Free system is the industry's most advanced anticorrosive function, effective for both steel and hard metals.

Super hard material (G5)

Rust-less system	Used	Not Used
8-hour machining in water (Machining) + 5-day leaving in water (Not machining) (T10 x 25 x 25 mm) Electrode: HQ-Wire ø 0.20 mm Dielectric fluid: Water		

Ferrous material (NAK55 raw material)

Rust-less system	Used	Not Used
3-hour machining in water (Machining) + 3-day leaving in water (Not machining) (T25 x 25 x 70 mm) Electrode: HQ-Wire ø 0.20 mm Dielectric fluid: Water		

DSM (Dynamic Shape Master)

OPTION 8

For exceptional and extreme geometries the DSM (Dynamic Shape Master) is an optional function for Premium series to perform accurate and efficient wire-cut EDM machining.

Advantages of DSM:

- Excellent cutting stability at extreme stepped portions, pockets and through-holes
- 2 independent flushing pumps
- Enhanced accuracy and surface finish
- Improved cutting speed

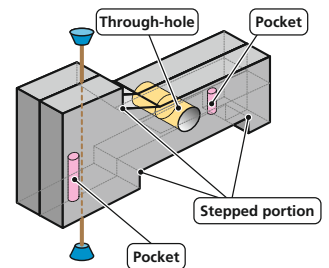

Material	SKD11
Workpiece thickness:	18 to 60 mm (Up & down contact/Both floating/One side floating)
Surface finish	0.40µmRz
Number of cutting	5-time cutting
Electrode	Brass wire ø 0.20 mm
Machining time	1st cut= 1h 22min, total 3h 10min

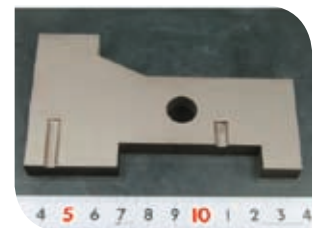

Features of DSM

DSPC (Dynamic Shape Preview Control)	Workpiece geometry preview and NC data creation by importing 3-D model through Intelligent Q ^{vic} EDW
TC2 (Thinking Circuit 2)	Automatic workpiece thickness detection during machining and automatic cutting condition adjustment
AFC (Active Flow Control)	Independent control of upper/ lower flushing nozzles
FTC2 (Finish thinking circuit)	Finishing cut for TC2
The "KANTAN 2" (including HS control)	User-friendly machining condition search software for TC2

■ = for both specification

■ = only for Premium specification

Specification AG400L/AG600L

Specification Of Machine	AG400L	AG600L
Max. workpiece dimensions (W x D x H)	600 x 470 x 240 mm	800 x 570 x 340 mm
Max. workpiece weight	500 kg	1000 kg
Work tank size (W x D)	850 x 610 mm	1050 x 710 mm
X-/Y-/Z- axis travel	400 x 280 x 250 mm	600 x 380 x 380 mm
U axis x V axis travel	120 x 120 mm	120 x 120 mm
Taper angle (workpiece thickness of 100mm)	±25° (±45° option)	±25° (±45° option)
Wire diameter	0.10~0.30*1 mm	0.10~0.30*1 mm
Wire feed speed (max)	420 mm/sec	420 mm/sec
Wire tension	3~23 N	3~23 N
Distance from floor to table top	995 mm	995 mm
Machine tool dimensions (W x D x H)	2100 x 2235 x 2220 mm	2460 x 2620 x 2390 mm
Machine installation dimensions	3200 x 3200 mm	3500 x 3700 mm
Machine tool weight	3800 kg	4950 kg
Total power input	Normal: 10,5 KVA*2 / Max: 13 kVA	Normal: 10,5 KVA*2 / Max: 13 kVA

Due to ongoing research, specifications are subject to change without prior notice / *1 Option: ø 0.05, ø 0.07 mm / *2 Indicates the electric capacity when ø 0.2mm wire is used.

Dielectric Tank	AG400L	AG600L
External dimensions (W x D)	650 x 2080 mm	725 x 2550 mm
Weight (empty)	400 kg	600 kg
Capacity	600 lit	800 lit
Dielectric filtration system	Replaceable paper filter (internal pressure 3-shell type)	Replaceable paper filter (internal pressure 3-shell type)
Deionizer	Ion exchange resin (18-lit container)	Ion exchange resin (18-lit container)

Features	AG400L	AG400L Premium	AG600L	AG600L Premium
Linear Motor Driver	●	●	●	●
Absolute Linear Scale	●	●	●	●
Sodick Motion Control	●	●	●	●
Ceramic Components	●	●	●	●
Super Jet AWT	●	●	●	●
Wire Tension Servo	●	●	●	●
Electrolysis Free Circuit	●	●	●	●
Dielectric Chiller	●	●	●	●
High Speed Generator	–	●	–	●
S-PIKA-W	–	●	–	●
Intelligent Q ^{vic} EDW	–	●	–	●
TC2	–	●	–	●
UPS	□	●	□	●
Taper Flex 45	□	□	□	□
Jumbo Feeder	□	□	□	□
L-Cut (Wire Chopper)	□	□	□	□
Automation	□	□	□	□
Indexing Table	□	□	□	□
Fine Wire diameter Ø 0.05 / 0.07 mm	□	□	□	□
HTP high voltage circuit	□	□	□	□
ANCS	–	□	–	□
DSM (Dynamic Shape Master)	–	▲	–	▲
8-axis Simultaneous	▲	▲	▲	▲

● Standard ▲ Factory Option □ Option – Not available

CNC Power Supply LN2W / LP2WH / LN20W/ LP20WH			
Max. machining current	60A (LP) 40A (LN)	Display type	15.1" TFT-LCD Touch Screen (XGA)
Power requirement	200/220V 50/60Hz	Character set	Alphanumeric and symbols
CNC unit	Multi-task OS, Sodick Motion Controller	Simultaneously controlled axes	Max. 4 axes (LN20W, LP20WH Max 8 axes)
User memory capacity	Edit: 100,000 blocks / saving: 30MB	Min. input command	0.01µm
Memory device	CF Card, External Memory	Min. drive unit	0.01µm
Input format	USB part, LAN, Touch Screen, Keyboard	Drive mechanism	Linear motor

AG400L

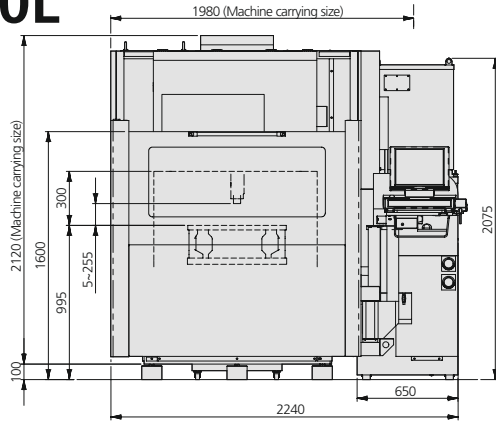

Front

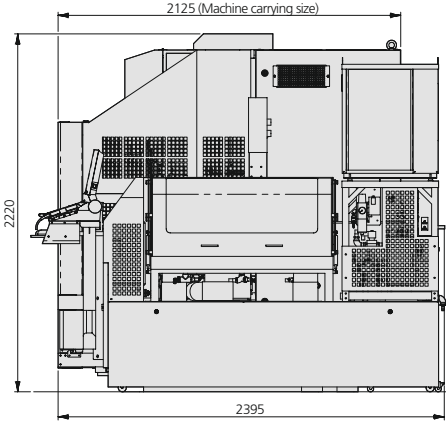

Side

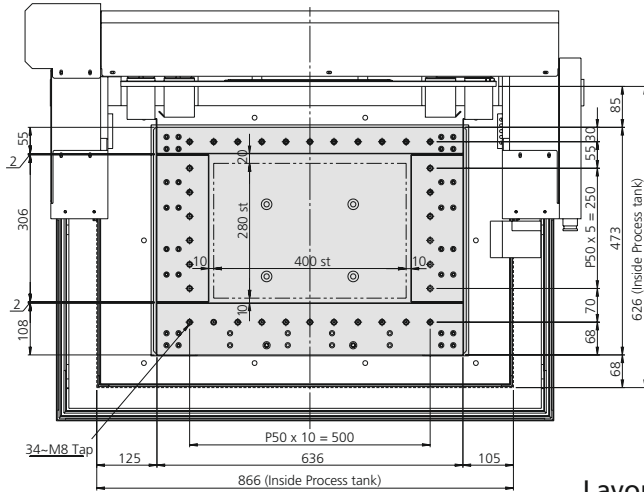

Work Table

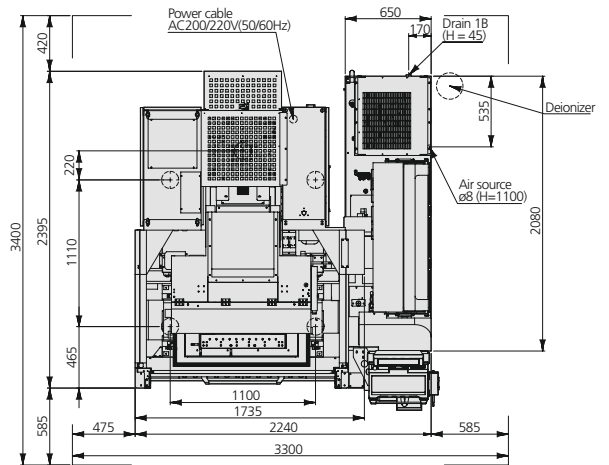

Layout

AG600L

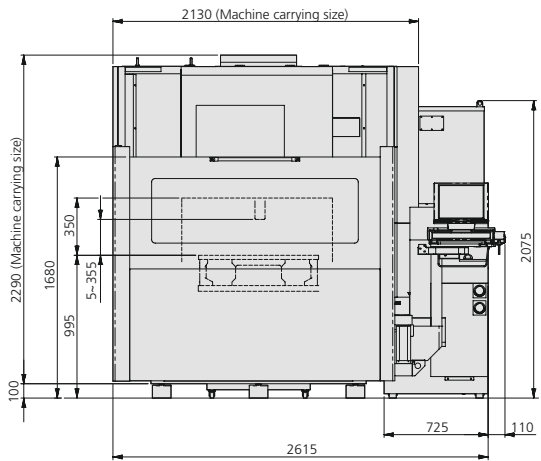

Front

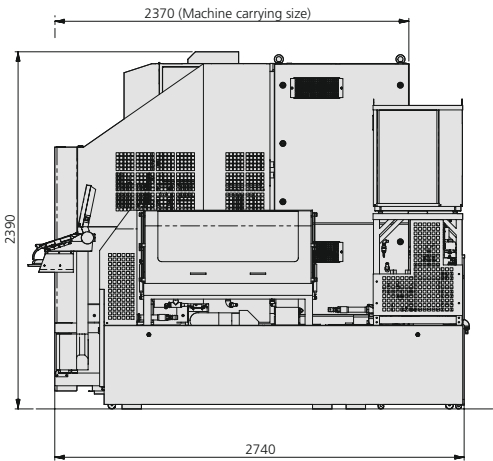

Side

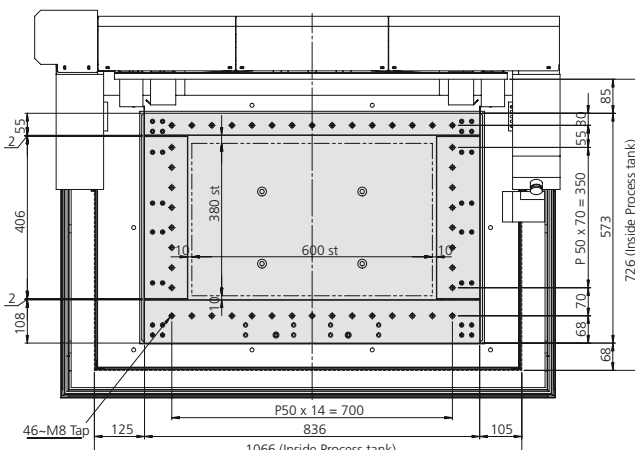

Work Table

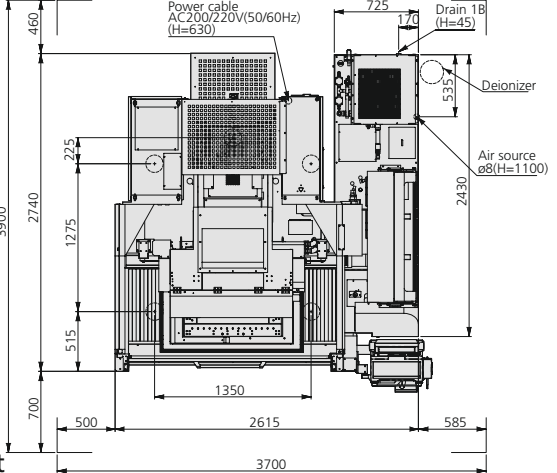

Layout

· All CE spec machines have external transformer with dimension of ca. 650 x 460 x 540mm

Sodick

create your future

Sodick Europe Ltd.

Rowley Drive, Baginton
Coventry, CV3 4FG
United Kingdom

Phone +44 (0) 24 7621 4314
Fax +44 (0) 24 7630 5680

Sodick Contact

email europa@sodick.eu.com
online www.sodick.org